



AUTOMATIC ENTRANCE SPECIALISTS

GTC
Automatic systems
for curved sliding doors



Automatic pedestrian doors

Automatic systems for curved sliding doors

The **GTC** automatic system belongs to the famous and numerous **GT** family. As in the case of its "sister" range of automatic systems, maximum rationality of design is clearly visible in the way it makes the curved sliding movement as simple and harmonious as possible. Indeed, **GTC** is used to automate

important and aesthetically glamorous entrances, where the sliding of the automatic doors must not disturb the overall harmony with brusque movements.

The utilization of the tried and tested technology of thousands of **GT** installations has not only enabled **GTC** to obtain harmonious movements, but

also to be able to offer constant reliability over long periods of time. Furthermore, a "belt-driven" movement enables **GTC** to obtain larger opening passages, with the same radius, in comparison to other door-moving systems; this enables the designer to make better use of the space available for the entrance.



GTC installation example

DITEC offer two supply options:

GTC

The automatic system alone is supplied complete with:

- geared motor
- electronic control panel with microprocessor
- sliding guide track made by anodized aluminium section bar
- galvanized steel sliding carriages with nylon wheels
- belt and cable for door movement

- connections for door leaves
 - floor guide track
 - structural metalwork
 - door-locking device complete with manual release
 - battery-operated anti-panic device.
- A range of control and safety accessories are also available in order to better satisfy the practical requirements of the automatic entrance.

GTC A

The mobile or mobile + fixed door leaves, available unglazed or complete with 6/8/10 panes of safety laminated glass, are framed with special DITEC rolled and galvanized, or painted upon request, aluminium section bars, including the front casing.

Sections

The **GTC** range represents a real innovation in the field of automatic systems with curved sliding door leaves.

Indeed the basic design philosophy is inspired by the possibility of being able to create "ad hoc" doors, with radii of curvature suitable to achieve total architectural integration.

Indeed, by combining the various types of automatic systems it is possible to obtain numerous configurations, capable of satisfying all transit requirements whilst always guaranteeing the entrance highly prestigious touches.



The vertical "belt" movement enables extremely wide opening passages to be obtained, making better use of the available space.

Vertical section

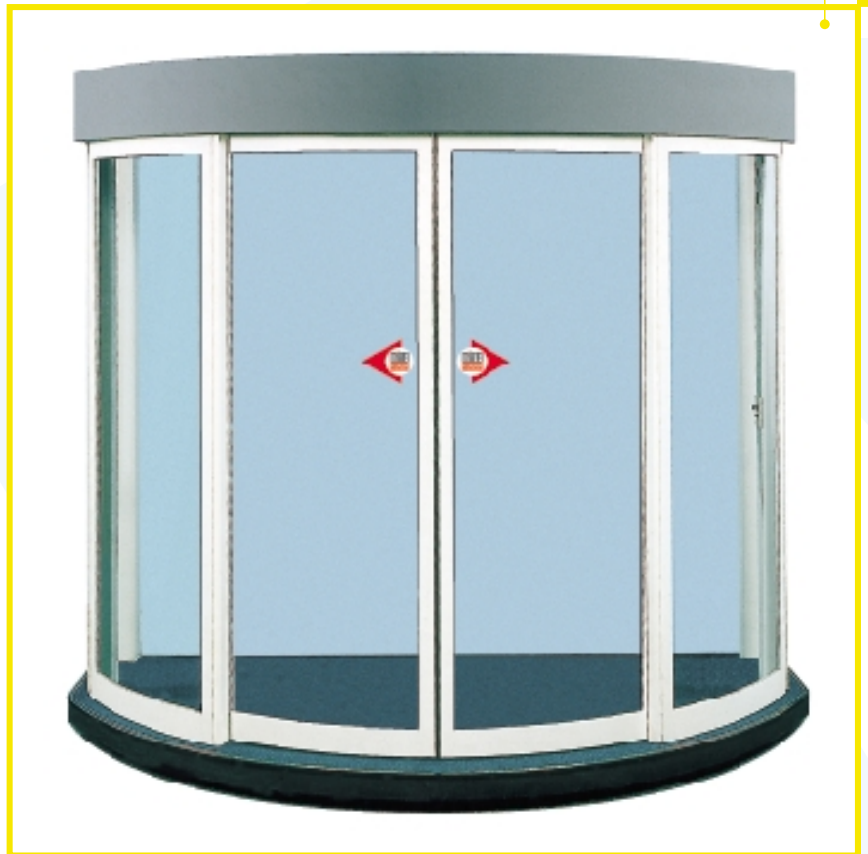
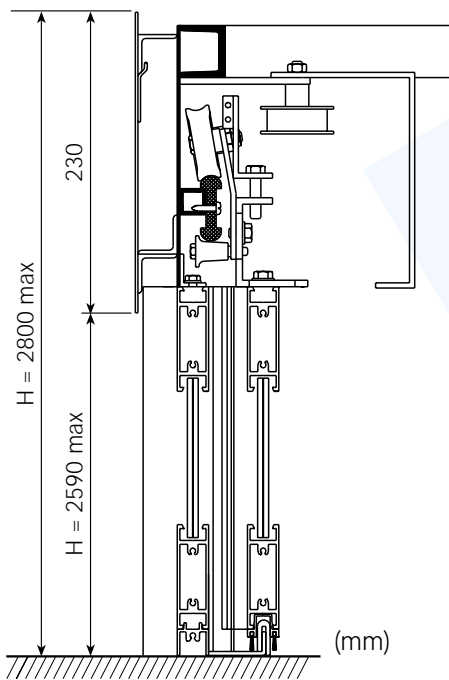

Horizontal section

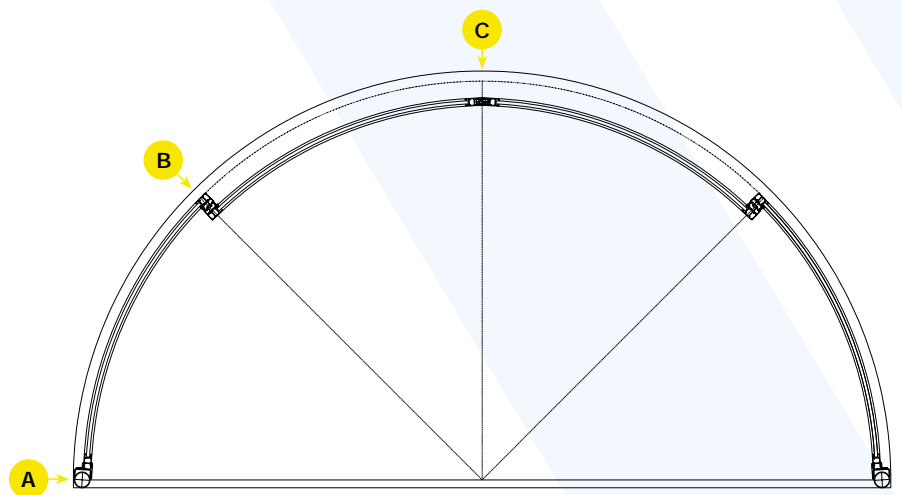
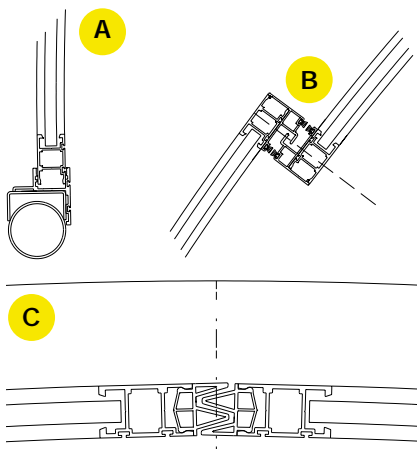

Some examples of dimensioning

Circular automatic system with two 120° door leaves

R external	VP opening passage	A	B
1100	1000	1905	550
1200	1100	2078	600
1300	1200	2252	650
1400	1300	2425	700
1500	1400	2598	750
1600	1500	2771	800
1700	1600	2945	850
1800	1700	3118	900
1900	1800	3290	950
2000	1900	3464	1000

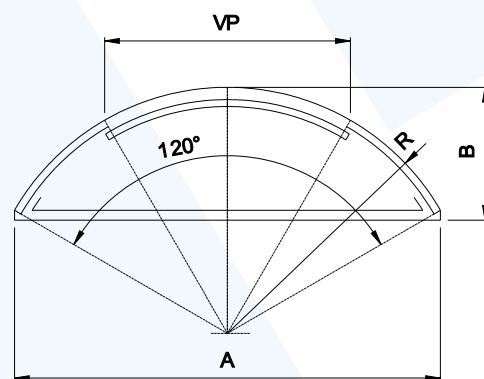

Circular automatic system with two 180° door leaves

R external	VP opening passage	A	B
900	1160	1800	950
1000	1300	2000	1050
1100	1440	2200	1150
1200	1580	2400	1250
1300	1720	2600	1350
1400	1880	2800	1450
1500	2000	3000	1550
1600	2140	3200	1650
1700	2280	3400	1750
1800	2420	3600	1850
1900	2560	3800	1950
2000	2700	4000	2050

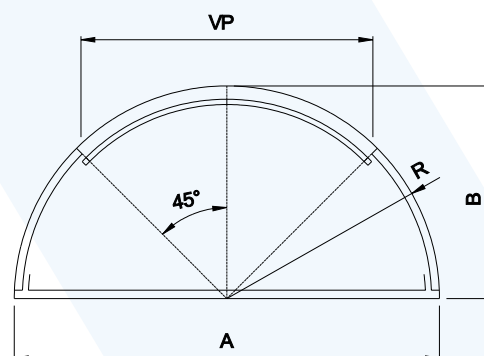

Circular automatic system with two 240° door leaves

R external	VP opening passage	A	B
900	1380	1800	1400
1000	1560	2000	1550
1100	1730	2200	1700
1200	1900	2400	1850
1400	2250	2800	2150
1600	2590	3200	2450
1800	2940	3600	2750
2000	3280	4000	3050

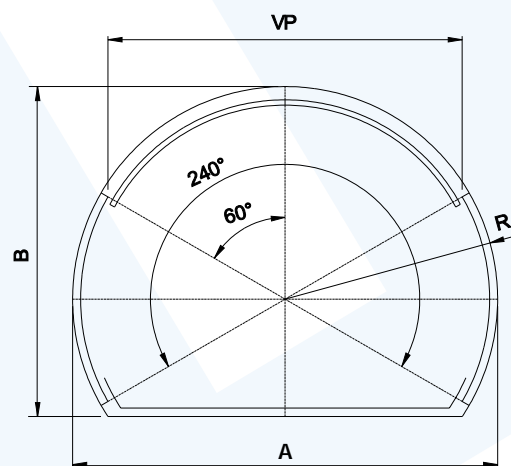

Dimensions

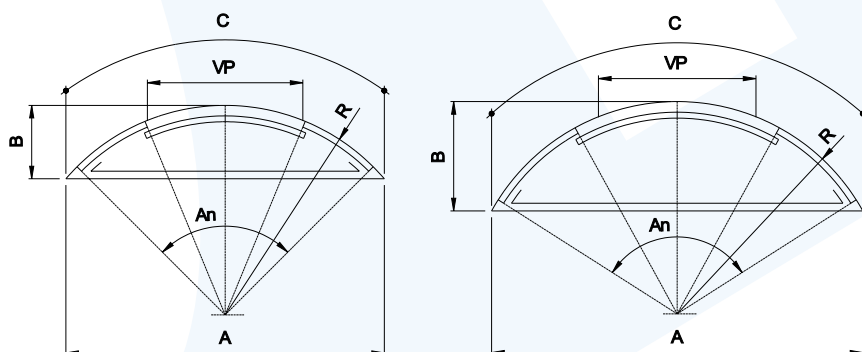

It is possible to create different compositions of the automatic system by modifying the parameters according to requirements, keeping arc C as the limit. (max = 5000 mm).

The illustrations and information which appear in this leaflet are not to be considered binding. Always consult DITEC S.p.A. before making an order or an estimate.

Typical installation

Installation diagram of an automatic door with curved sliding leaves. Arrangement instructions for electrical installation.

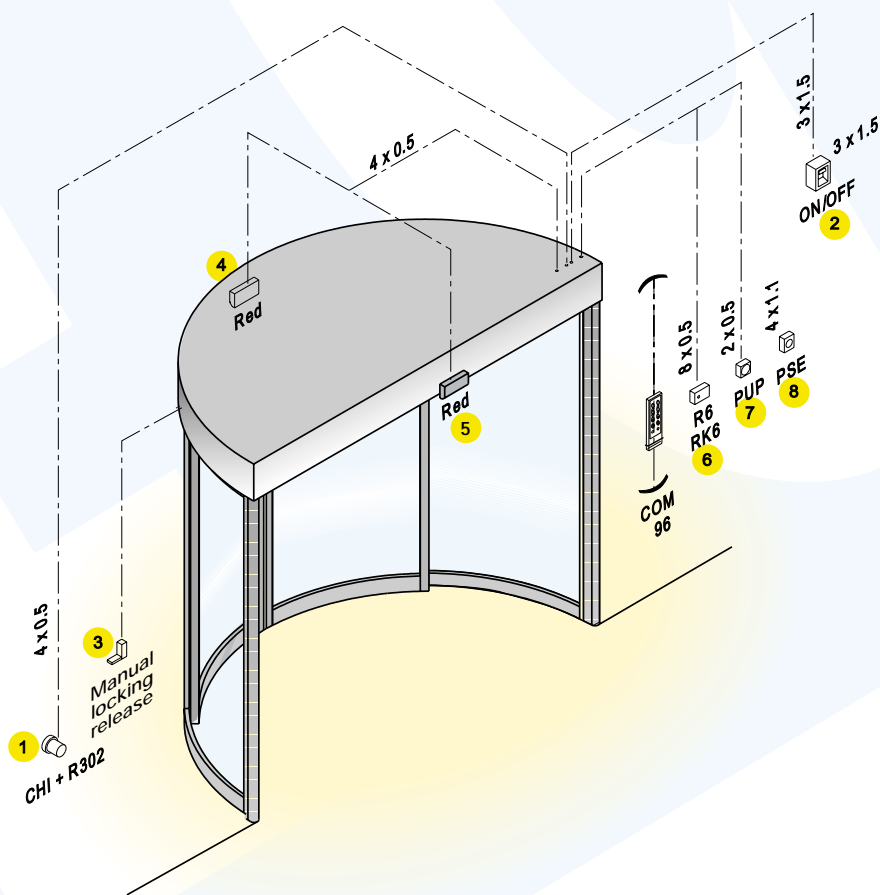

Key

- 1 Control key
- 2 230 V AC power supply
- 3 Manual locking release
- 4 Detection device
- 5 Detection device
- 6 Photocell amplifier
- 7 Function selector
- 8 Emergency switch

Devices and accessories

Switches: key, emergency, mechanical crank and pneumatic.

Control systems: keypad, digital combination or proximity.

Mechanical function programmes with or without key lock.

Detection device: operating with active infrared rays.

Push-button control panel: table and wall-mounted.

Detection device: operating with one-way or two-way microwaves.

Floor platforms of various sizes.

Electronic multifunction programmer with additional safety functions for access control.

Microwave and infrared detection devices

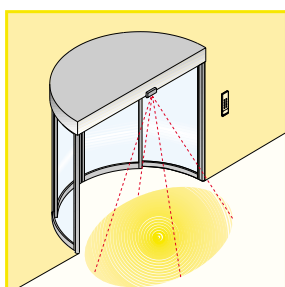

Floor platforms

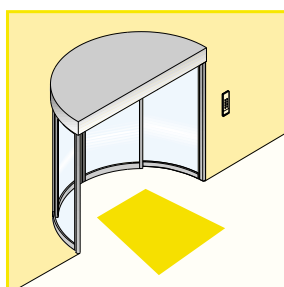

Bush-button panels

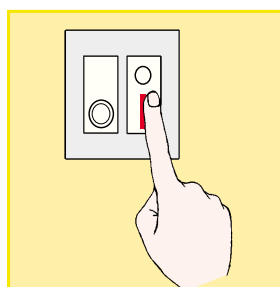

Function programmers

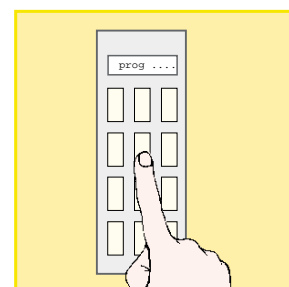

Technical specifications

Functioning	Continuous operation
Sliding	On reinforced nylon wheels
Traction	By means of a toothed belt made from a synthetic electricity-conducting material and steel cable
Structure	Steel load-bearing framework with aluminium sliding tracks
Maximum opening speed	0.7 m/s (1 leaf) – 1.4 m/s (2 leaves)
Closing speed	Approximately 70% of the set opening speed
Approaching speed	0.1 m/s
Power supply	230 V AC 50 Hz (120 V AC 60 Hz upon request)
Motor	24 V DC with encoder
Emergency operation	With 24 V DC supplementary batteries
Maximum current absorbed 230 V	1 A
Electric control panel	With microprocessor logic. Supplied as standard inside the automatic system
Power supply for accessories	24 V DC 0.5 A
Anti-crushing device	Electronic with encoder. Supplied as standard.
Controls	Manual/Automatic. One/Two-way. Door open/closed. Total/partial opening.
Adjustments	Manual and automatic with trimmer and dip switch.
Manually adjustable functions	Opening/closing speed. Traction force. Partial opening. Length of time door remains open (0-30 s).
Automatic self-adjusting functions	Maximum opening/closing limits. Traction force according to adjustment set. Obstacle detection with successive intelligent movement.
Maximum load (continuous operation)	150 kg total leaves.
Minimum radius	900 mm

Regulations: DITEC automatic systems possess the EC mark and are designed and built in compliance with the safety requirements of the Machines Directive (89/392/EEC), the Electromagnetic Compatibility Directive (89/336/EEC) and the Low Voltage Directive (73/23/EEC).

DITEC S.p.A. reserve the right to make modifications aimed at improving the products.

Specification for curved door complete with leaves

Curved automatic door, complete with mobile and fixed leaf/leaves composed of: GTC model automatic system for curved doors with painted steel load-bearing structure; aluminium sliding track; steel carriages with reinforced nylon self-lubricating silent wheels; 24 V DC geared motor with encoder;

electronic control panel with microprocessor logic; traction system composed of toothed belt and steel cable; painted wooden closure covers which can be opened for inspection; door leaf-locking device with manual release and battery-operated emergency opening device supplied as standard; painted steel-

front covering band; mobile and fixed door leaves made from special DITEC extruded anodized or RAL-painted aluminium section bars, complete with curved safety laminated glass panes and nylon floor tracks.

Specification for curved door automatic system only

GTC model automatic system for curved doors with painted steel load-bearing structure; aluminium sliding track; steel carriages with reinforced nylon self-lubricating silent wheels; 24 V DC geared

motor with encoder; electronic control panel with microprocessor logic; traction system composed of toothed belt and steel cable; painted wooden closure covers which can be opened for inspec-

tion; door leaf-locking device with manual release and battery-operated emergency opening device supplied as standard. Painted steel-covered front covering band can also be supplied.

DITEC S.p.A.

Via Mons. Banfi, 3
21042 Caronno P.Illa (VA) Italy
Tel. +39 02 963911 - Fax +39 02 9650314
www.ditec.it

Il marchio P.A. è di proprietà della DITEC S.p.A.



ISO 9001
Cert. n° 0957/0

